

LOC		DIST		REVISIONS			
GP	00	REV	DATE	BY	CHK	APPV	
D2	REVISED PER ECO-12-014371		15NOV2012	CJV	PAR		

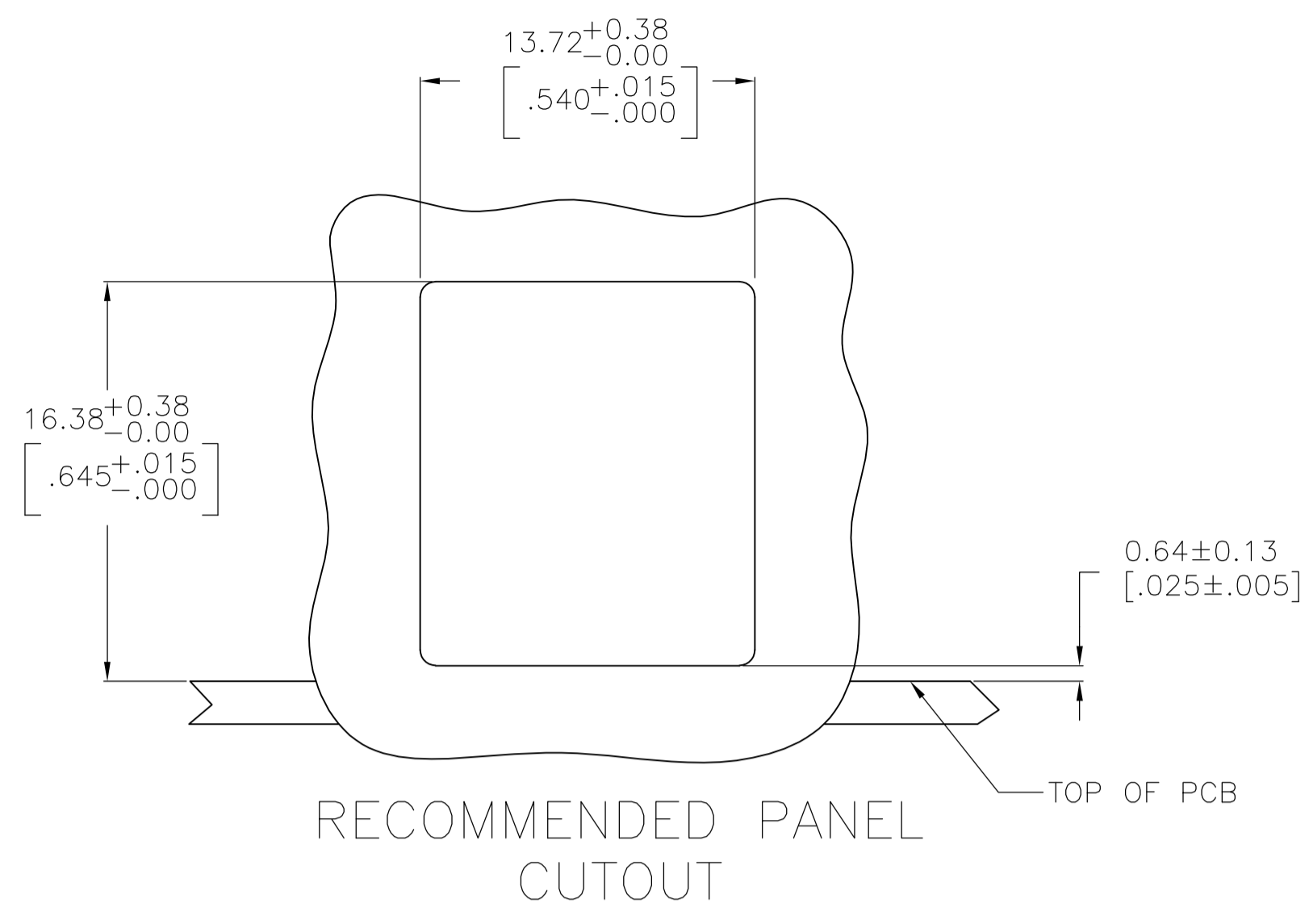

- MATERIAL:
HOUSING - PBT POLYESTER, COLOR: BLACK
TERMINAL - 0.36[.014] THICK PHOS BRONZE PLATED WITH (SEE TABLE) MIN HARD GOLD IN LOCALIZED GOLD PLATE AREA AND 2.03µm[.000080] MIN THICK MATTE TIN IN SOLDER AREA OVER 1.27µm[.000050] MIN THICK NICKEL UNDERPLATE
- CAVITY CONFORMS TO FCC RULES AND REGULATIONS PART 68 AND REA BULLETIN 345-81, PE-76 SPECIFICATION FOR MODULAR TELEPHONE HARDWARE.
- 0.15µm[.000006] GOLD PLATED PARTS DO NOT MEET THE MINIMUM GOLD THICKNESS REQUIREMENT OF FCC SPECIFICATION, PART 68. PARTS HAVE NOT BEEN TESTED TO THE DURABILITY REQUIREMENTS OF TE PRODUCT SPEC 108-1163
- TERMINALS FOR 5520250-1 AND -2 LOCATED IN CENTER POSITIONS
- DIMENSIONS ARE MAXIMUM UNLESS OTHERWISE SPECIFIED

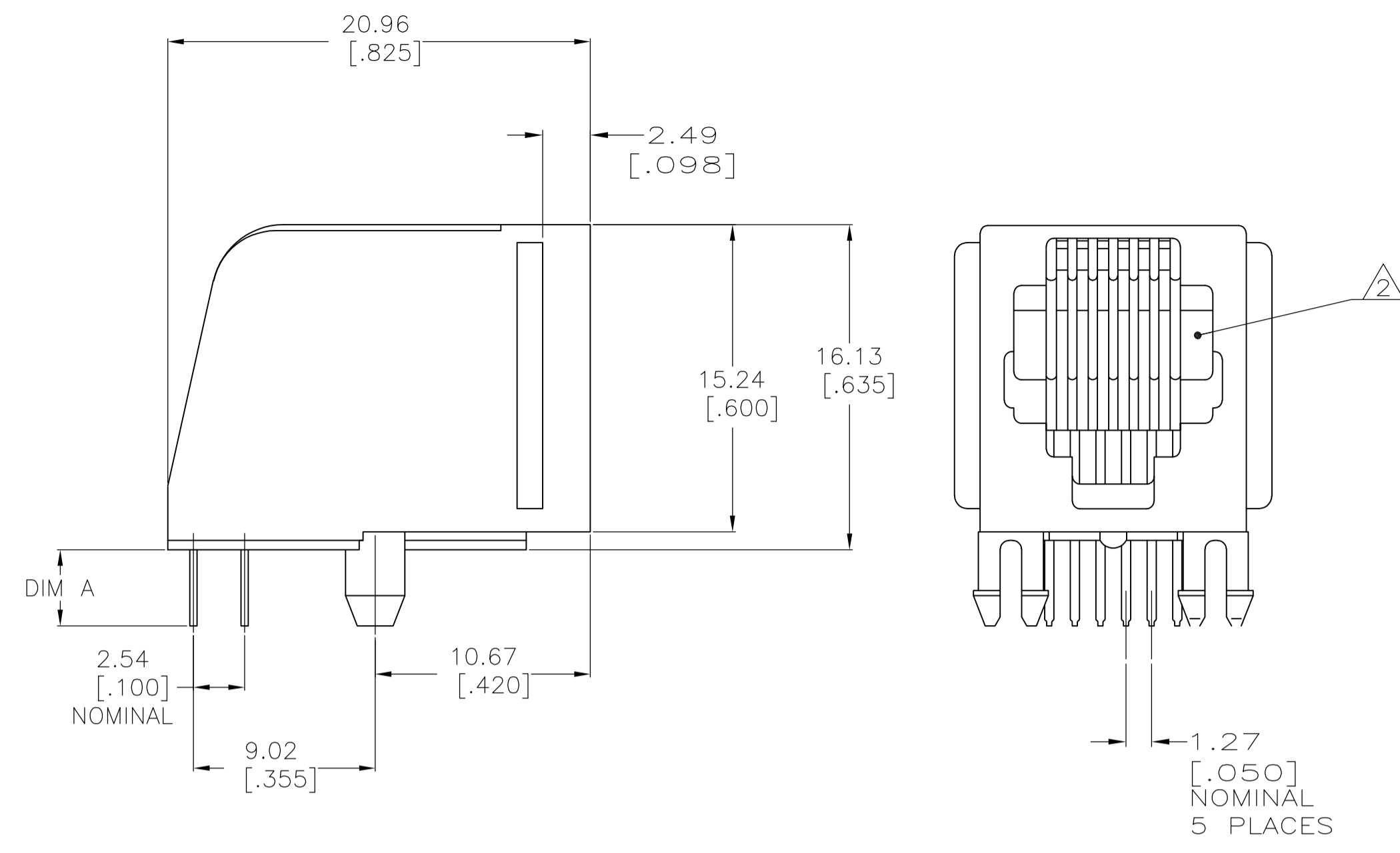
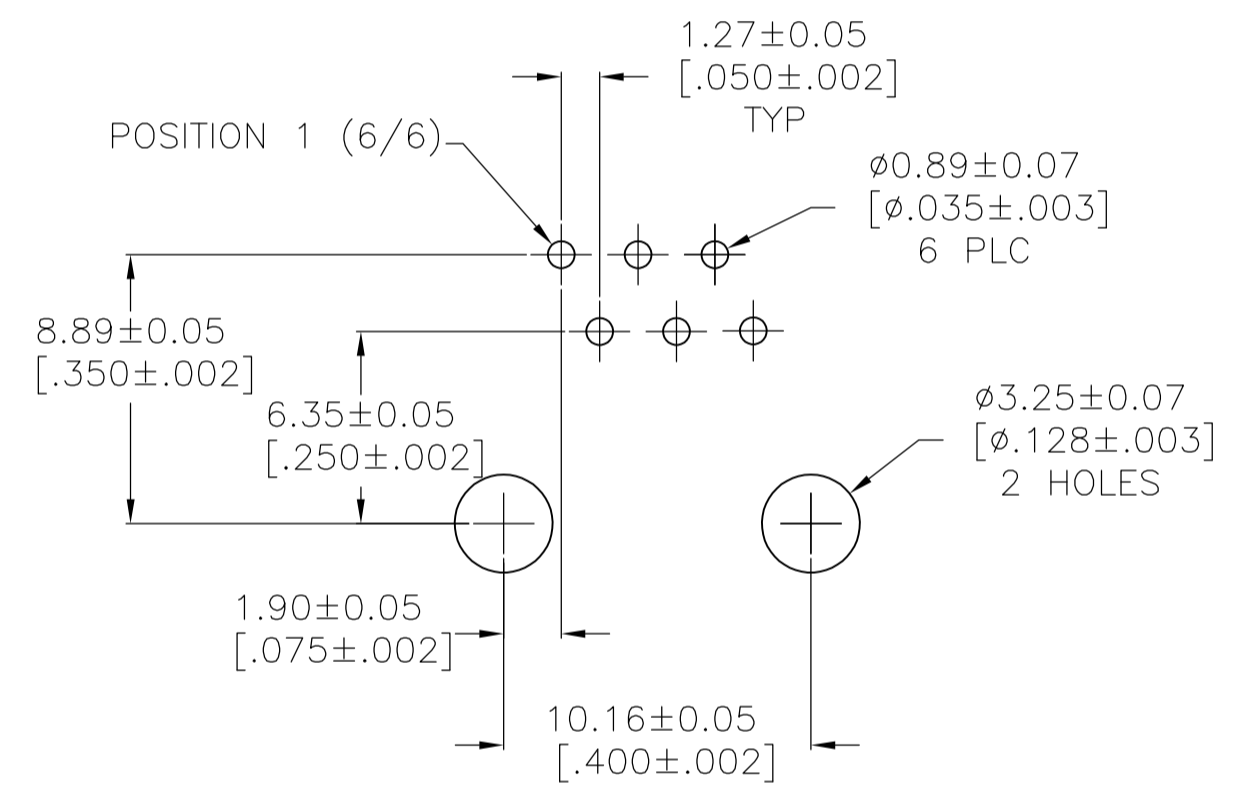
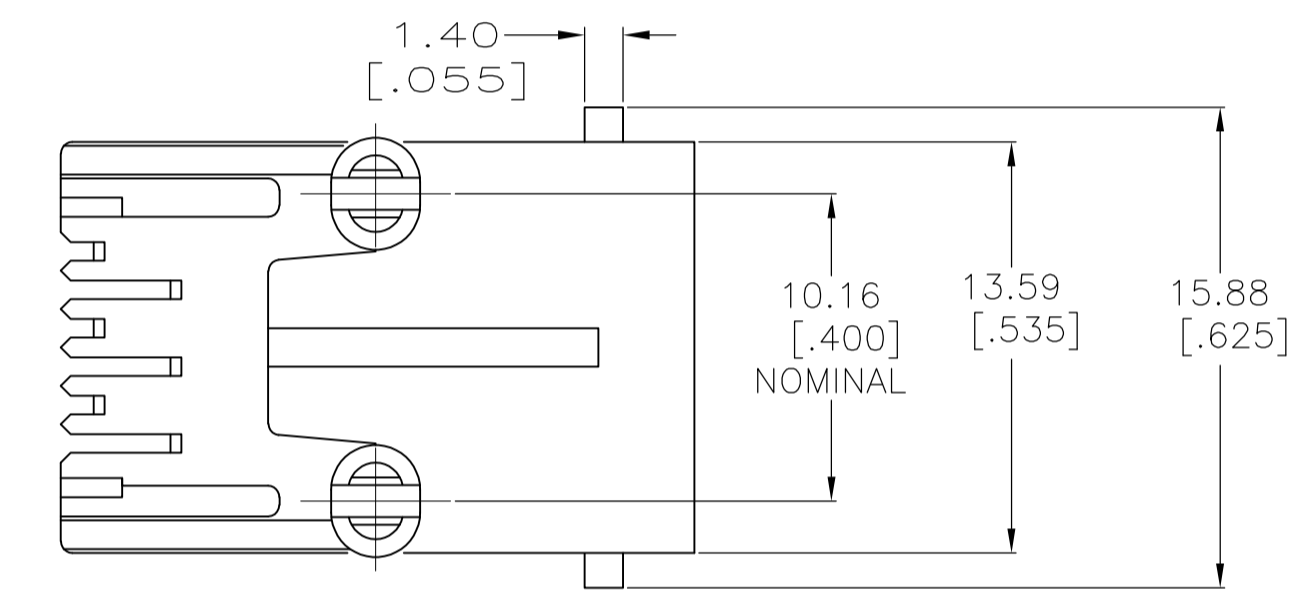

RECOMMENDED PRINTED CIRCUIT BOARD LAYOUT COMPONENT SIDE SHOWN

OBSOLETE	0.15µm[.000006]	3.30-4.32 [.130-.170]	6	2-5520250-3
			4	2-5520250-2
		2.16-2.67 [.085-.105]	4	1-5520250-1
	1.27µm[.000050]	3.30-4.32 [.130-.170]	6	5520250-3
			4	5520250-2
			2	5520250-1
	GOLD THICKNESS	DIM A	TERMINALS REQUIRED	PART NUMBER

THIS DRAWING IS A CONTROLLED DOCUMENT.

DIMENSIONS: mm [INCHES]	TOLERANCES UNLESS OTHERWISE SPECIFIED:	DIN T. WOOTEN/L.A. MAYER 12MAY2005	CHK J. WESTMAN 12MAY2005	APVD S. FLICKINGER 12MAY2005	NAME
	0 PLC ± -				MODULAR JACK ASSEMBLY, 6 POSITION, SIDE ENTRY, FLANGELESS, WITH PANEL STOPS
	1 PLC ± -				PRODUCT SPEC 108-1163
	2 PLC ± 0.13[.005]				APPLICATION SPEC 114-2048
	3 PLC ± -				SIZE CAGE CODE DRAWING NO RESTRICTED TO
	4 PLC ± -				A1 00779 C=5520250
	ANGLES ± -				WEIGHT -
MATERIAL SEE NOTE 1	FINISH SEE NOTE 1	WEIGHT -	SCALE 4:1	SHEET 1 OF 1	REV D2

CUSTOMER DRAWING